

INSTALLATION INSTRUCTIONS

DESCRIPTION: GYTR Radiator Brace Kit
PART NUMBER: BHR-E24C0-V0
MODEL: 2023 YZ450F



⚠ WARNING

Please read and understand these instructions completely before installation to avoid possible injury, or damage to the accessory or vehicle.

WARRANTY INFORMATION:

In the United States, contact your dealer of purchase for information, fitment advice and a copy of the Yamaha Genuine Parts and Accessories Limited Warranty for this accessory.

NOTICE:

Installation of this kit requires a torque wrench and should be performed by an authorized Yamaha dealer or a qualified mechanic. -

DEALER OR INSTALLER:

These instructions contain important information for future reference and *must* be given to the customer. -

PARTS LIST:

No.	Part Number	Description	Qty
--	BHR-E24C0-V0	Radiator Brace Kit	
①	*	Radiator Brace LH	1
②	*	Radiator Brace RH	1
③	90105-06170	M6x16 Flange Bolt	4

* Part supplied with kit only and not available separately.

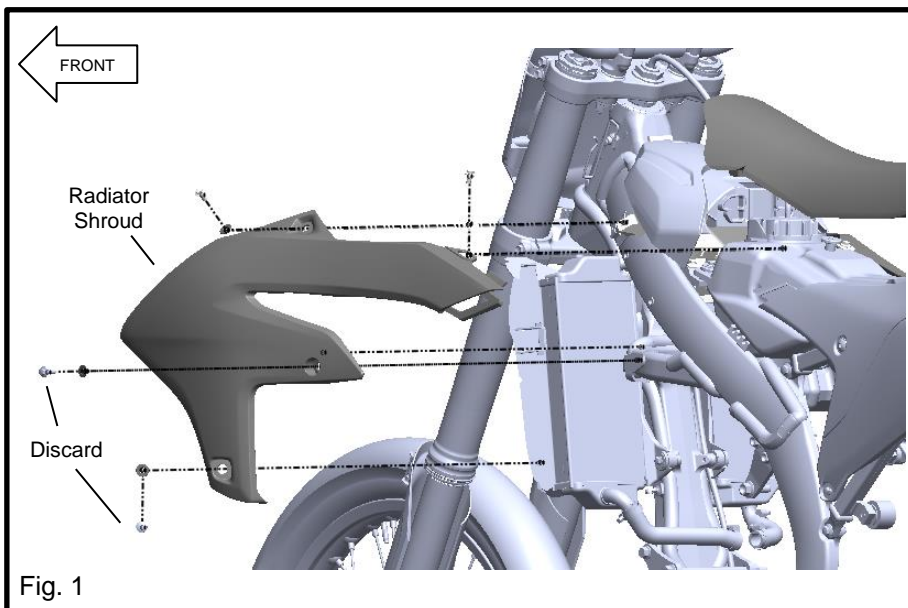
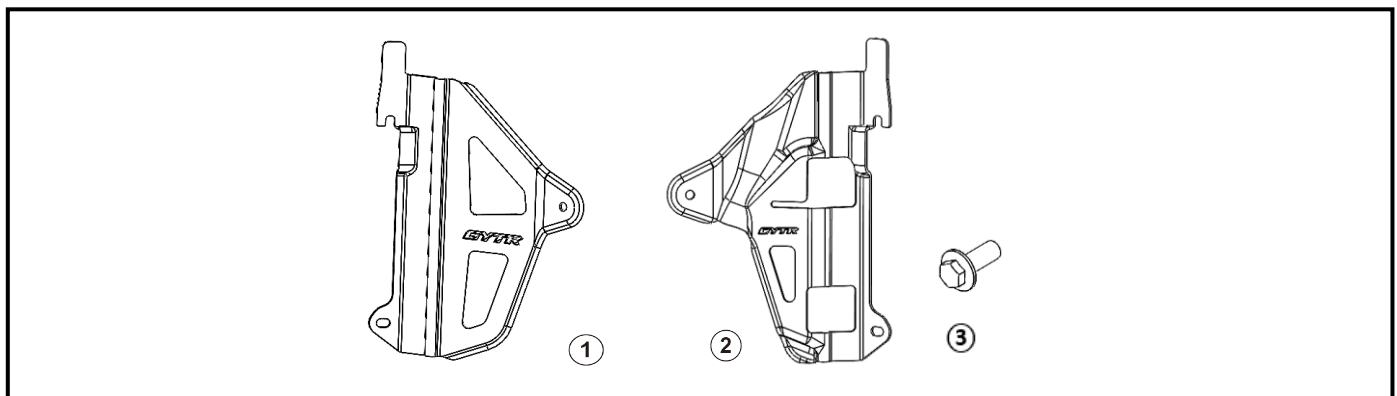

PREPARATION: -

1. Place the vehicle on a secure and level surface. Set the parking brake.
2. Clean the mount surfaces before beginning installation.

Installation:

1. Remove the rider's seat (refer to owner's manual for this process)
2. Remove the left and right-side radiator shrouds and retain the hardware except for the bolts to be discarded as shown in Fig. 1 and Fig. 2.

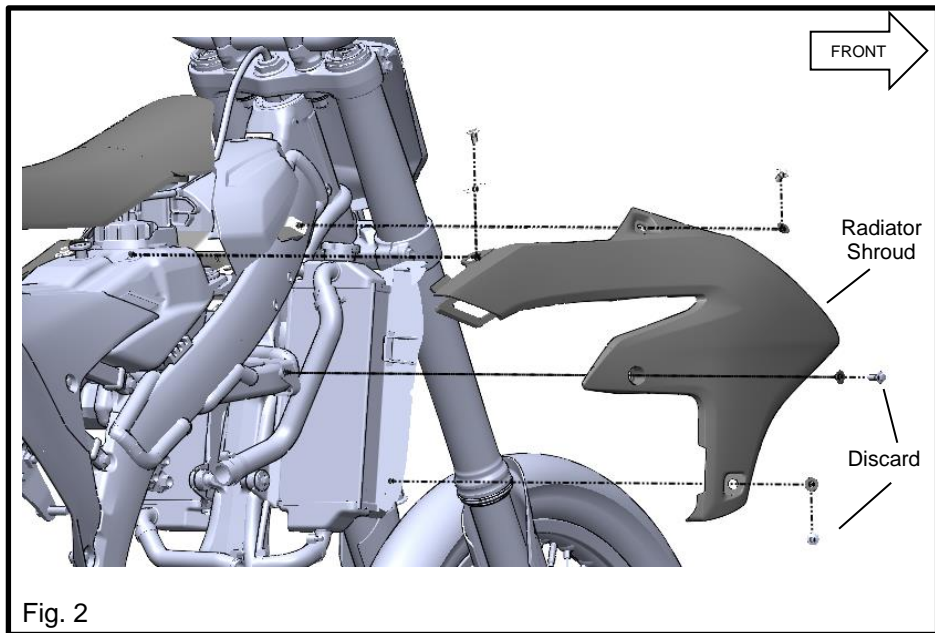

Fig. 2

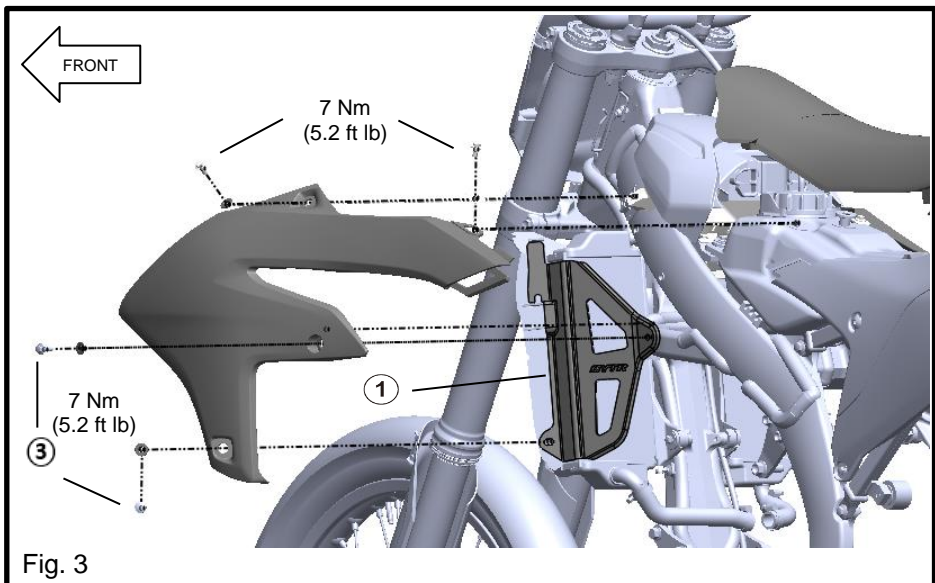

Fig. 3

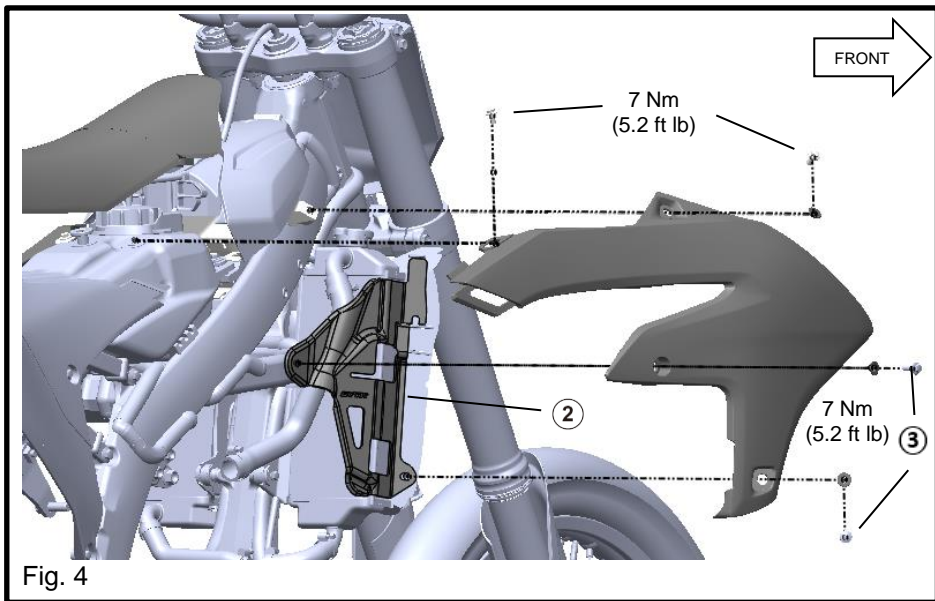

Fig. 4

3. Install ① Radiator Brace LH, ② Radiator Brace RH, left and right-side radiator shrouds with retained hardware and ③ M6 Flange Bolts as shown in Fig. 3 and Fig. 4

MAINTENANCE:

Periodically, check torque on all hardware. If loose hardware is found, re-torque to specification.

CARE AND CLEANING:

Clean metal parts with a clean, soft cloth and mild soap and water solution. Rinse and dry.

CUSTOMER SERVICE:

For further information see your Yamaha dealer.

**ESTIMATED TIME TO INSTALL:
0.5 HRS.**